

A Network Analyzer System for Pulse Profile Measurements

Thilo Bednorz,

Rohde&Schwarz, 1 ESP, Muehldorfstrasse 15, 81671 Munich, Germany, +49 89 4129 13412
Thilo.Bednorz@rsd.rohde-schwarz.com

Abstract — A novel approach is presented for a measurement system that is able to investigate the behavior of microwave circuits and components under pulsed conditions. This technique is integrated into a vector network analyzer to measure not only power levels but also scattering parameters of short pulses. In comparison to other systems, it does not need periodical pulses and does not require complicated and expensive hardware to chop the signals for subsequent pulse reconstruction.

I. INTRODUCTION

Vector network analyzers are traditionally used to measure the continuous wave (CW) S-parameter performance of components. Under these operating conditions the analyzer is functioning as a narrowband measurement instrument. It transmits a known CW frequency to the component and measures the CW frequency response.

In some cases the signal applied to the component must be pulsed (turned on and off) at a specific rate and duration. Beside measuring the parameters versus frequency or power under pulsed conditions, the user often wants to know the behavior of the DUT versus time during the pulse.

The time resolution of network analyzers analyzing pulsed signals or S-parameters of pulsed signals is limited not only by the available bandwidth but also by the processing time between two data points. Current network analyzers have bandwidths up to 1 MHz and sampling and processing time less than 3 μ s. However, time resolution in the 100 ns range could only be achieved with additional hardware that chops the pulsed signal to reconstruct the pulse profile later.

II. DESCRIPTION

With the network analyzer ZVA from Rohde&Schwarz and its pulse profile function, the pulse profile can be analyzed with a resolution below 100 ns. The down converted IF signal is only band-limited by the analog bandwidth of the frontend what is about 30 MHz. The signal is A-D converted with a sampling rate of 80 MHz.

Normally a network analyzer feeds the sampled data of the wave quantities to the digital filters of a DSP for further processing. To eliminate the processing time the sampled data is diverted to a fast memory (RAM). There, the data is recorded and stored without filtering. After finishing the recording process, the data is filtered offline by the ZVA firmware to derive the raw S-parameters and to apply error correction.

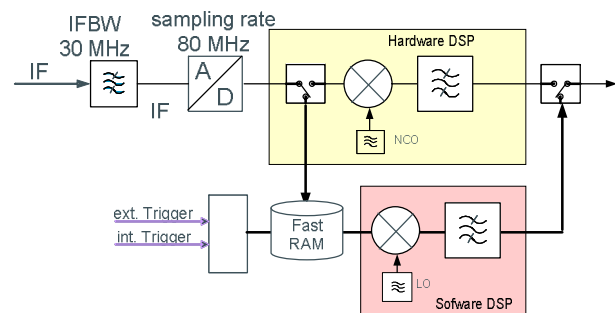

Fig. 1. Signal flow for pulse profile test

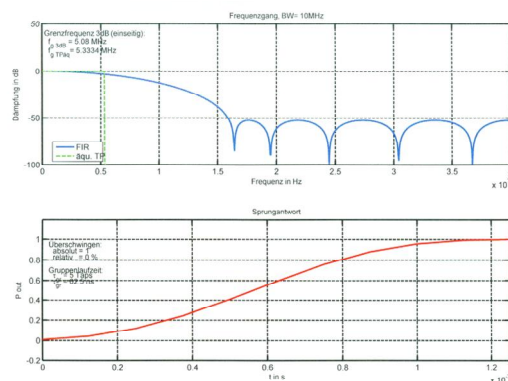

Fig. 2. Frequency and step response of the 10 MHz “offline” filter

The sampling rate of 80 MHz provides a time resolution of 12,5 ns. The memory capacity allows a total recording time of 3 ms. The data is continuously transferred from

the A/D converter to the fast RAM. The time reference 0 can be set by an external trigger signal, which typically is the rising edge of the pulsed RF signal. Thus events before a trigger or rising edge of the pulse can be detected and analyzed.

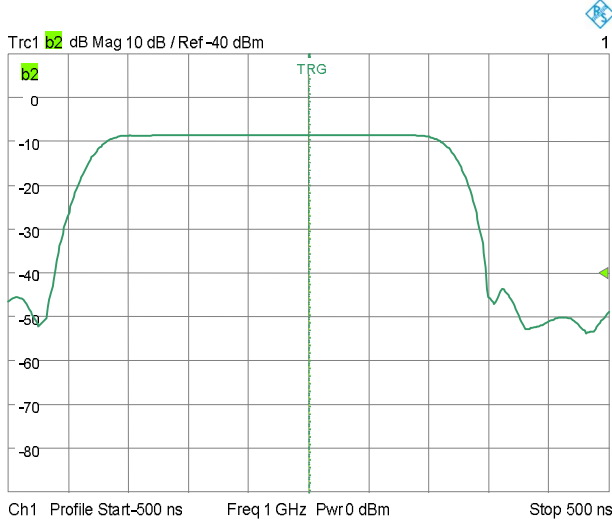

Fig. 3. Pulse profile of a wave quantity

For DUTs with large group delay that is higher than the pulse width, it is difficult or even impossible to measure S_{21} because the reference signal a_1 is already off before the transmitted pulse reaches the b_2 receiver.

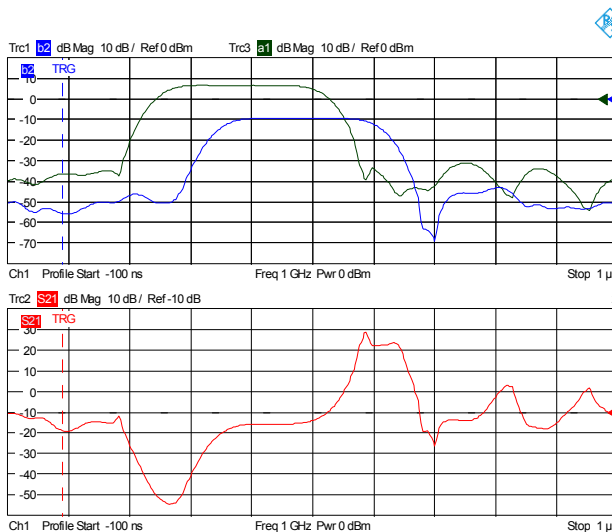

Fig. 4. Wave quantities of a_1 , b_2 and S_{21} of a DUT with 100 ns group delay.

This problem can be solved by shifting mathematically the individual waves by the group delay of the DUT before calculating the S-parameters. Thus DUTs with high group delay can be analyzed also with very short pulses.

Fig 5 shows the result after shifting the b_2 wave by 100 ns.

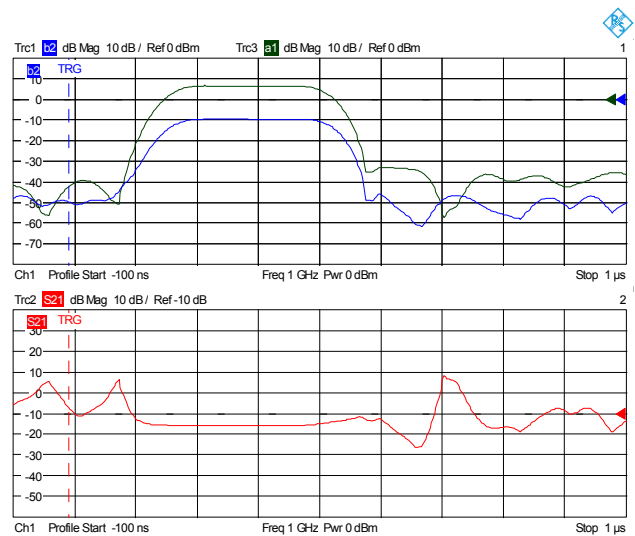

Fig. 5. S_{21} after shifting b_2 by 100 ns

III. TEST SETUPS

For applications that need a pulsed RF signal, a pulsed generator e.g. the SMR from Rohde&Schwarz can be used. The ZVA's testset has direct access to the generator path via the front panel, which can be used to feed in an external modulated source instead of the internal CW source.

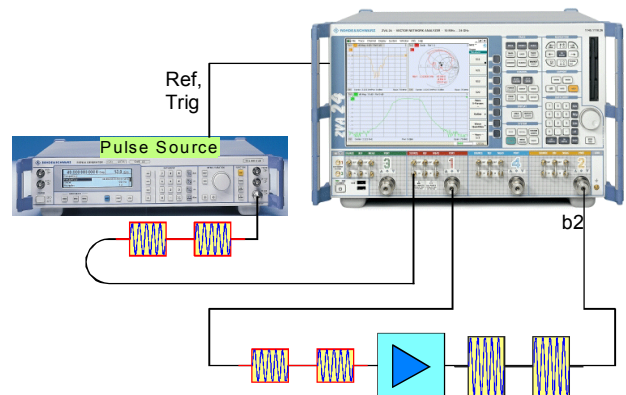

Fig. 6. Using a pulsed RF-generator as pulsed source

Because the signal passes through the coupler and is sampled by the reference receiver, calibrated S-parameters such as S_{11} and S_{21} can be measured. The setup does not require recalibration if pulse parameters like the duty cycle are changed. A calibration performed in CW mode is also valid under pulsed conditions. Dynamic range is also independent of the duty cycle of the pulse.

This setup is suitable for pulsed measurements versus power or frequency, because external sources from R&S and other vendors can be controlled from the ZVA via the IEEE or LAN interfaces.

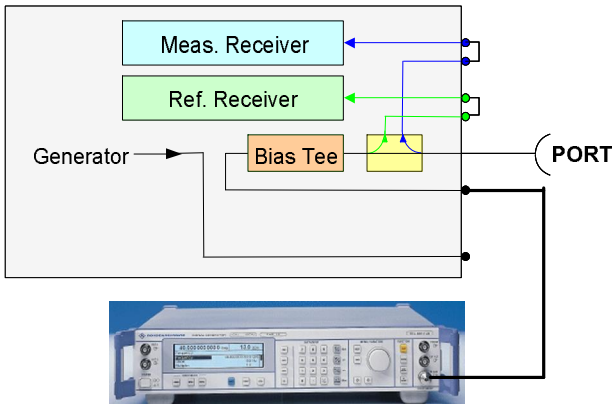

Fig. 7. Block diagram

Instead of a pulsed generator, a pulse modulator can directly be fed into the generator path to modulate the NWA's internal source.

If the DUT is pulsed itself, an arbitrary waveform generator is necessary as additional equipment.

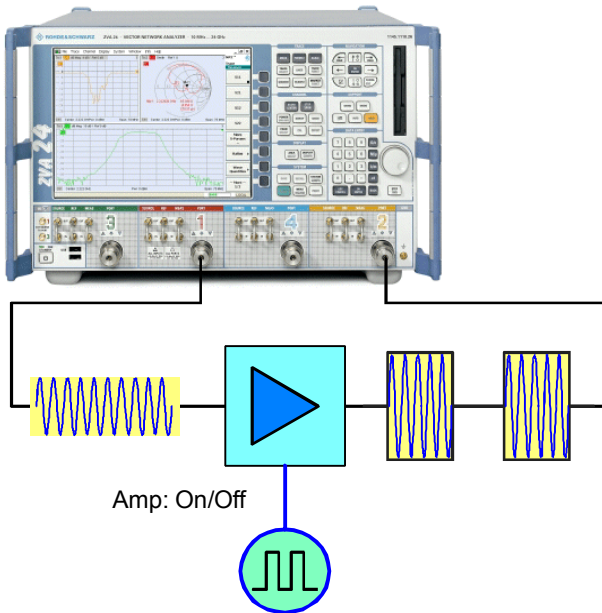

Fig. 8. Test Setup with pulsed DUT

IV. CONCLUSION

A practical network analyzer system for testing components under pulsed conditions has been described. The system is based on selective receiver with high IF bandwidth and a fast memory that records the raw data. These raw data are processed offline after the data recording. Changing the duty cycle of the pulse does not affect dynamic range and does not require recalibration. To generate a pulsed stimulus signal for pulsed power- and error corrected S-parameter measurements, an external pulsed RF-generator or an external pulse modulator can be fed into the network analyzers generator path.